

SANIFOS® 1600/2100/3100

STATION DE RELEVAGE À ENTERRER

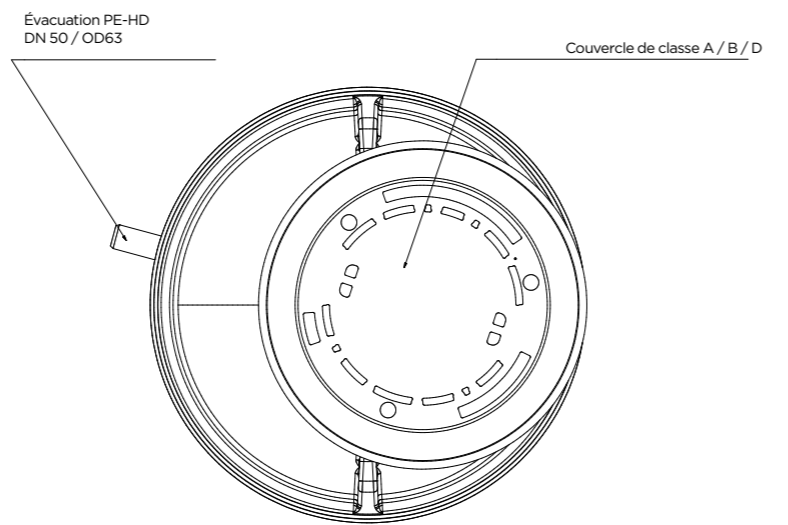
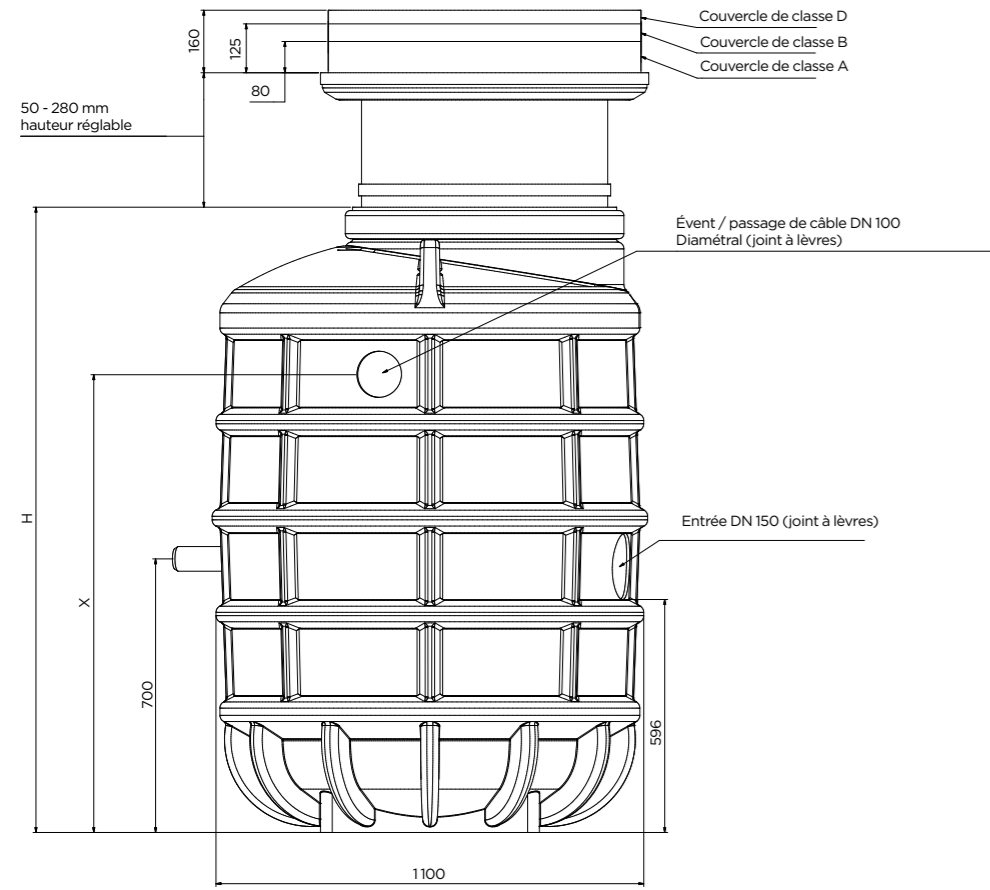

Hauteur de la cuve en mm	X
3 100	2 675
2 100	1 675
1 600	1 175